



Chapman Hybrid III

DOLLIES

Chapman-Leonard Studio Equipment has a long and storied history of innovation and expertise in the motion picture industry. Whites has several Chapman dollies, see some of the features of the Chapman Hybrid III below:

- Incorporates the universal stop valve system
- Nickel plated for less maintenance
- Built-in automatic hydraulic oil heating system
- Cam-lock chassis legs
- Compact and lightweight
- Interchangeable wheels for different terrain



Chapman Hybrid III

Maximum camera mount height	5'1"	(1.6m)
Minimum camera mount height (with Hybrid low camera 90° plate)	1"	(3cm)
Vertical travel	3'8"	(1.1m)
Maximum payload	500lbs	(227kg)
Maximum payload with high post kit	1900lbs	(863kg)
Maximum boom lifts (fully charged)	5 Lift	
Chassis maximum length (wheels fully extended)	4'6"	(1.4m)
Chassis minimum length (wheels fully retracted)	3'10"	(1.2m)
Minimum chassis height for transportation	1'6"	(46cm)
Chassis variable widths (legs in)	2'3"	(69cm)
Chassis variable widths (legs at 12° track position)	2'5"	(75cm)
Chassis variable widths (legs at 45°)	3'1"	(89cm)
Chassis variable widths (legs at 90°)	3'3"	(99cm)
Steering post height	3'	(91cm)
Minimum P turn radius	3'1"	(95cm)
Accumulator charging time (110 A.C. and D.C.)	Under 60 secs.	
Accumulator charging time (hand pump)	2.5 mins	
Minimum door width Hybrid can be carried through	1'6"	(46cm)
Carrying weight	395lbs	(179kg)
Standard optional weight (w/o payload)	463lbs	(210kg)
Hybrid III operational weight (w/high post kit w/o payload)	501lbs	(227kg)

Partners in Production®

VANCOUVER

CALGARY

WINNIPEG

TORONTO

SUDBURY

HALIFAX



Chapman Hybrid III

DOLLIES

MAXIMUM CAMERA MOUNT HEIGHT (WITH STANDARD 12" RISER).....	73"	1.9 M.
MAXIMUM CAMERA MOUNT HEIGHT (WITHOUT RISERS)	61¼"	1.6 M.
MINIMUM CAMERA MOUNT HEIGHT	15¼"	39 CM
MINIMUM CAMERA MOUNT HEIGHT (WITH HYBRID LOW CAMERA 90 DEGREE PLATE)	1"	3 CM
VERTICAL TRAVEL	44"	1.1M
*MAXIMUM PAYLOAD	500 LBS.	227 KG.
**MAXIMUM PAYLOAD WITH HIGH POST KIT	1,900 LBS.	883 KG.
MAXIMUM BOOM LIFTS (FULLY CHARGED)	5 LIFTS	
CHASSIS MAXIMUM LENGTH (WHEELS FULLY EXTENDED)	54"	1.4 M.
CHASSIS MINIMUM LENGTH (WHEELS FULLY RETRACTED)	46"	1.2 M
MINIMUM CHASSIS HEIGHT FOR TRANSPORTATION	18"	46 CM
CHASSIS VARIABLE WIDTHS - LEGS IN	27"	69 CM.
CHASSIS VARIABLE WIDTHS - LEGS AT 12 DEGREE TRACK POSITION	29½"	75 CM.
CHASSIS VARIABLE WIDTHS - LEGS AT 45 DEGREES	37"	89 CM
CHASSIS VARIABLE WIDTHS - LEGS AT 90 DEGREES	39"	99 CM
STEERING POST HEIGHT	36"	91 CM
MINIMUM P TURN RADIUS	37½"	95 CM.
ACCUMULATOR CHARGING TIME (110 A.C AND D.C)	UNDER 60 SEC	
ACCUMULATOR CHARGING TIME (HAND PUMP)	2½" MIN.	
MINIMUM DOOR WIDTH HYBRID CAN BE CARRIED THROUGH	18"	45 CM.
CARRYING WEIGHT	395 LBS	210 KG.
STANDARD OPTIONAL WEIGHT (W/O PAYLOAD).....	468 LBS	210 KG.
HYBRID W/HIGH POST KIT OPERATIONAL WEIGHT	501 LBS	227 KG

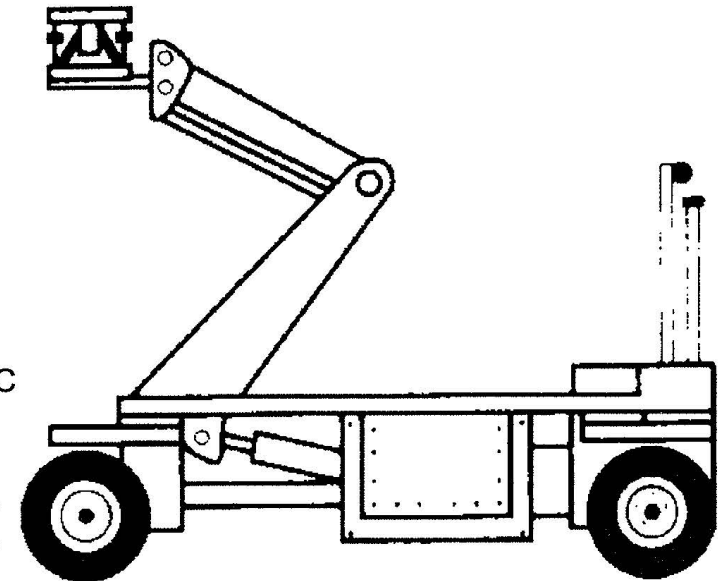

Partners in Production®